

Ottoman

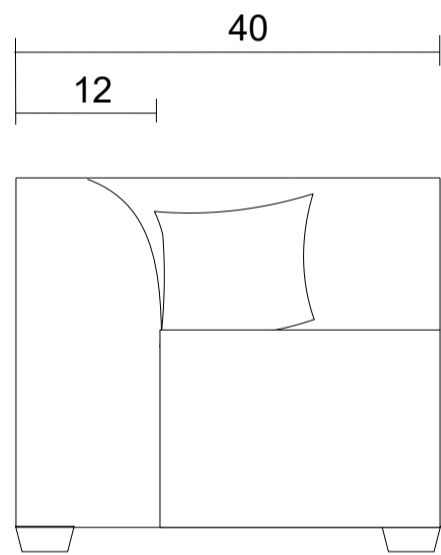

LHF Box Corner

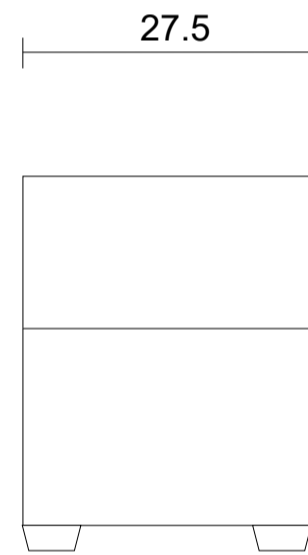

Armless Chair

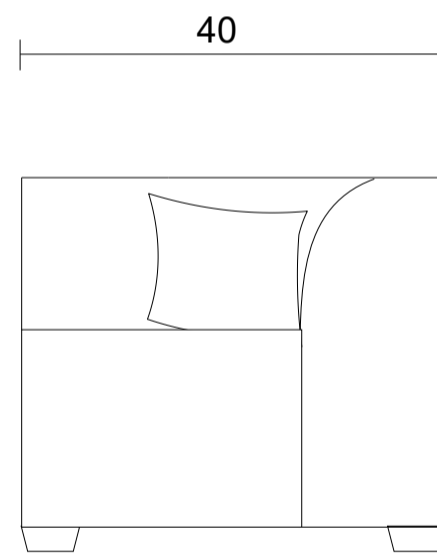

RHF Box Corner

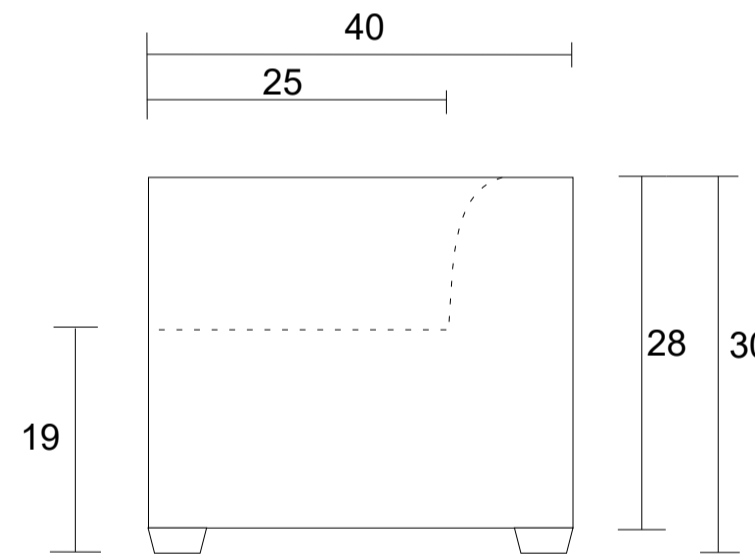

Sideview

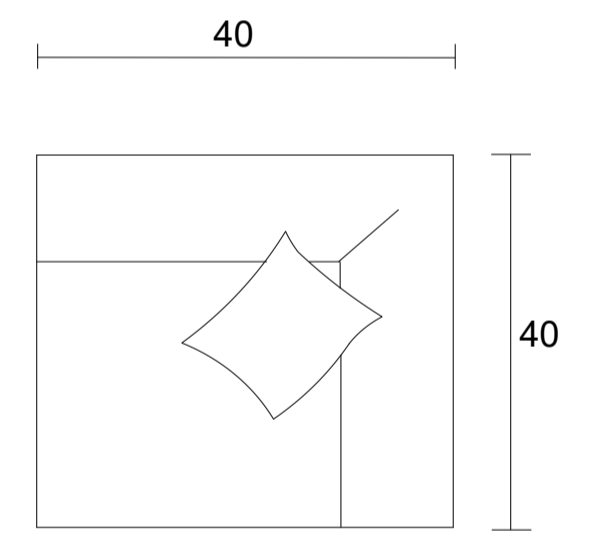

RHF Top view

Specifications:

- 2" square tapered leg in espresso, walnut or natural. Please specify on order
- 1 knife edge toss pillow (19" x 19") with zipper, accented up to grade G (per corner)
- No-Sag sinuous spring system with tight seat
- Tight back
- Schematic page should accompany order for sectional clip placement
- Measurements may vary +/- 1"
- March 11th, 2026

COM Requirement	Yards
LHF Box Corner	6.5
RHF Box Corner	6.5
Armless Chair	3.25
Ottoman	2.5

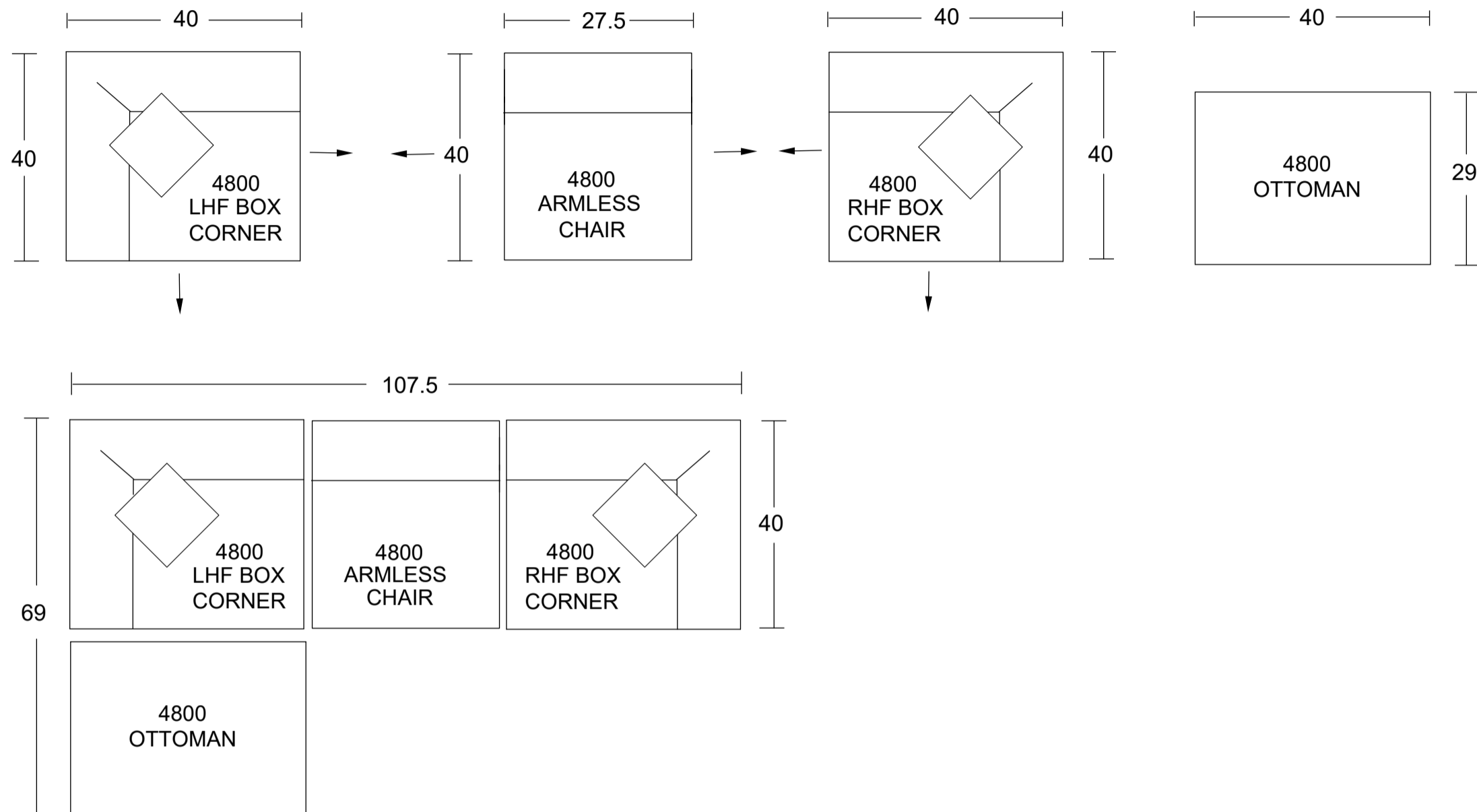

Specifications:

- 2" square tapered leg in espresso, walnut or natural. Please specify on order
- 1 knife edge toss pillow (19" x 19") with zipper, accented up to grade G (per corner)
- No-Sag sinuous spring system with tight seat
- Tight back
- Schematic page should accompany order for sectional clip placement
- Measurements may vary +/- 1"
- March 11th, 2026

COM Requirement	Yards
LHF Box Corner	6.5
RHF Box Corner	6.5
Armless Chair	3.25
Ottoman	2.5